

FOUNDATION REINFORCING SCHEDULE				
ASTM 615 - GRADE 60				
MARK	QTY	SIZE	LENGTH	WEIGHT (LBS)
HR1*	60	#4	18' - 7"	745
HR2	128	#5	9' - 3"	1235
HR3	168	#4	3' - 0"	337
Total Weight				2317
*Splice (3) HR1 to make 69'-4" in deck.				
CONCRETE SCHEDULE				
Approximate 12.75cu. yds. 4000 psi (min) concrete required.				
CLEARANCE (BOTTOM OF BEAM TO SLAB)				
21				

- GENERAL NOTES**
- Excavation, foundation forms, rebar, and concrete to be furnished by contractor or customer.
 - Foundation shown is designed for soils with a minimum bearing capacity of 1500 psf and adequate drainage. If soil conditions do not meet these requirements, adjust foundation or soil as required. The design is adequate for a highway surcharge of 300psf.
 - Work from centerlines when erecting forms and placing embedded items. Place anchor bolts within ±1/8" of positions indicated in drawing.
 - In areas of the country where there is severe freezing, increase the depth of the foundation so that the bottom extends below the frost line, or provide a minimum of 12" free draining granular material to prevent frost heave.
 - N.I.S.T. H-44 requires that on the entrance and exit ends of a vehicle scale, there shall be a straight approach that is:
 - At least the width of the platform.
 - The length of at least one-half the length of the platform but not required to be more than 40ft, and
 - Any slope in the remaining portion of the approach shall ensure ease of vehicle access, ease for testing purposes, and drainage away from the scale.
 - N.I.S.T. H-44 requirements and local weights and measures regulations may require installation parameters somewhat different than illustrated on this plan, particularly in regard to pit depth and approaches. In order to ensure compliance, consult the local Fairbanks service office prior to installation.
 - Refer to manual for all installation and operation instructions.
 - Fairbanks does not recommend using foundation or ground installed guide rails along the sides of the truck scale platform. Damage may occur to the scale if the vehicle hits the guide rail, transferring forces to the platform and the checking system. Usage of this style guide rail will void the product warranty.

- GROUNDING AND ELECTRICAL NOTES:**
- Install (2) 3/4" x 8'-0" long ground rods to project 4". Tie ground rods to slab rebar. Two ground rods are supplied with scale:
 - One for grounding Intalogix Power Supply. Position the ground rod to match the chosen location for the PPS. The PPS may be located at any section.
 - One for grounding scale weighbridge. Place within 3ft of a main beam, at any convenient location. The power supply ground must be separate from weighbridge ground, and should be at least 4'-0" from power supply ground.
 - Install minimum 1 1/2" conduit for cable from junction box to scalehouse. Suitable conduit for low voltage conductor shielded cable must pass through the wall at any point above pier tops that is convenient. Conduit to extend a minimum of 2" beyond the surface. Conduit is not supplied from the factory.
 - If alternating current (AC) is required near the scale, it shall not run closer than 36" in parallel with any load cell or other signal carrying cable.

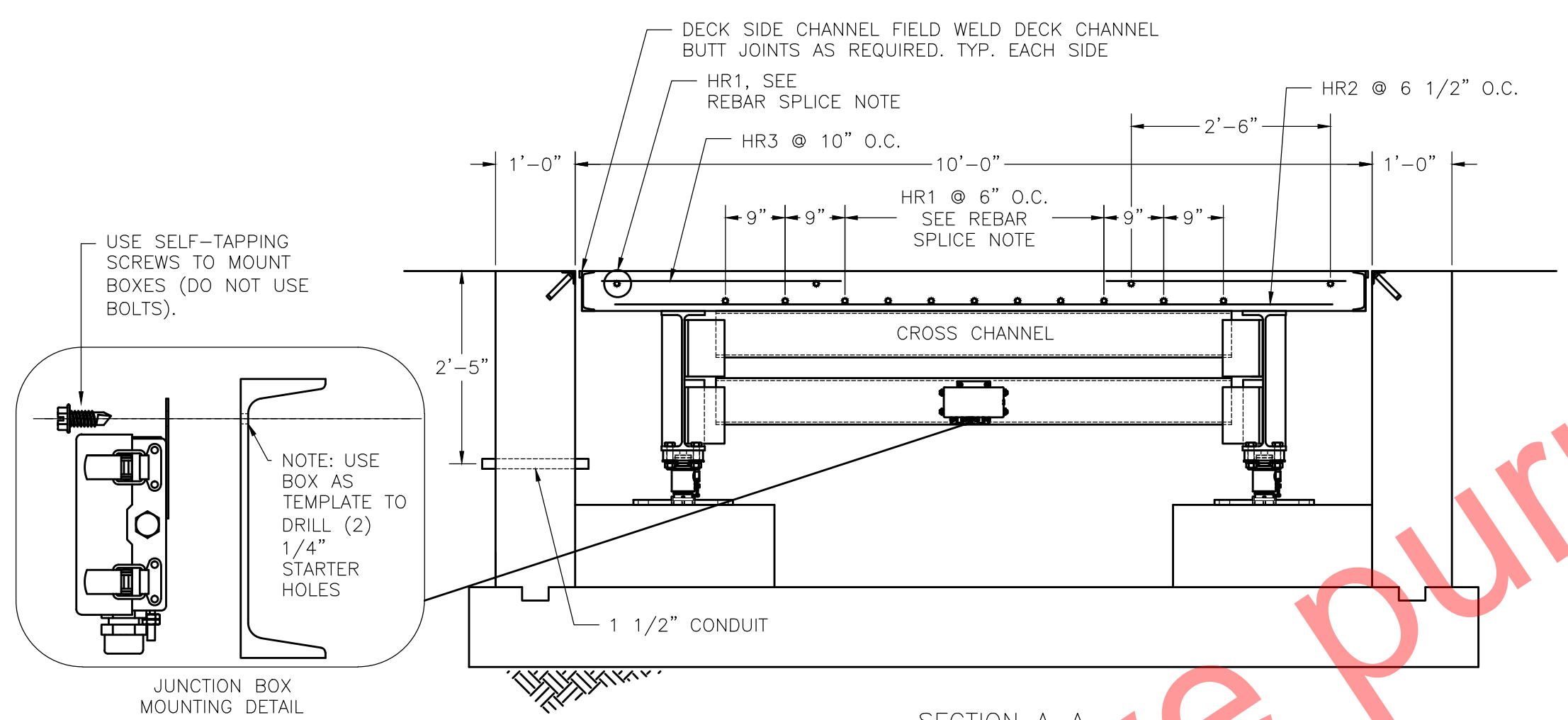

SECTION A-A

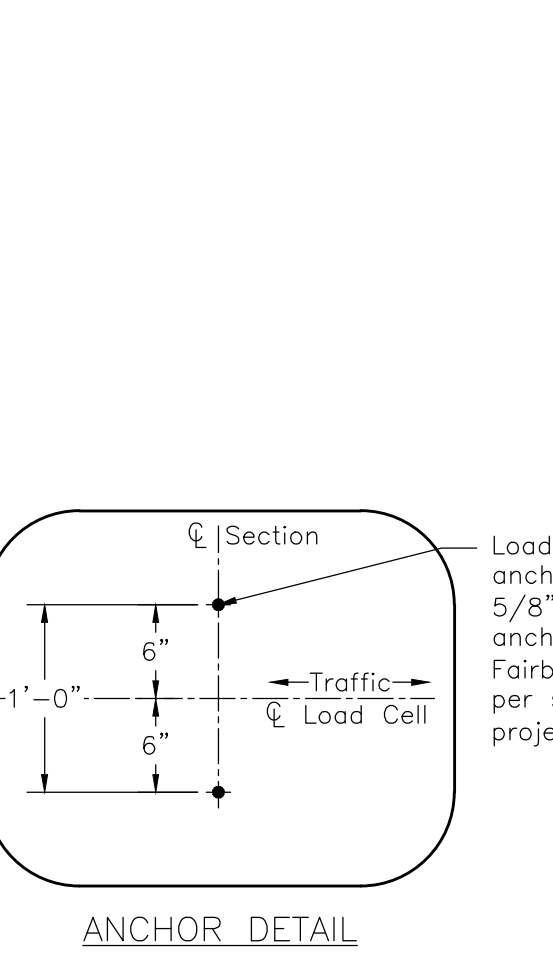

ANCHOR DETAIL

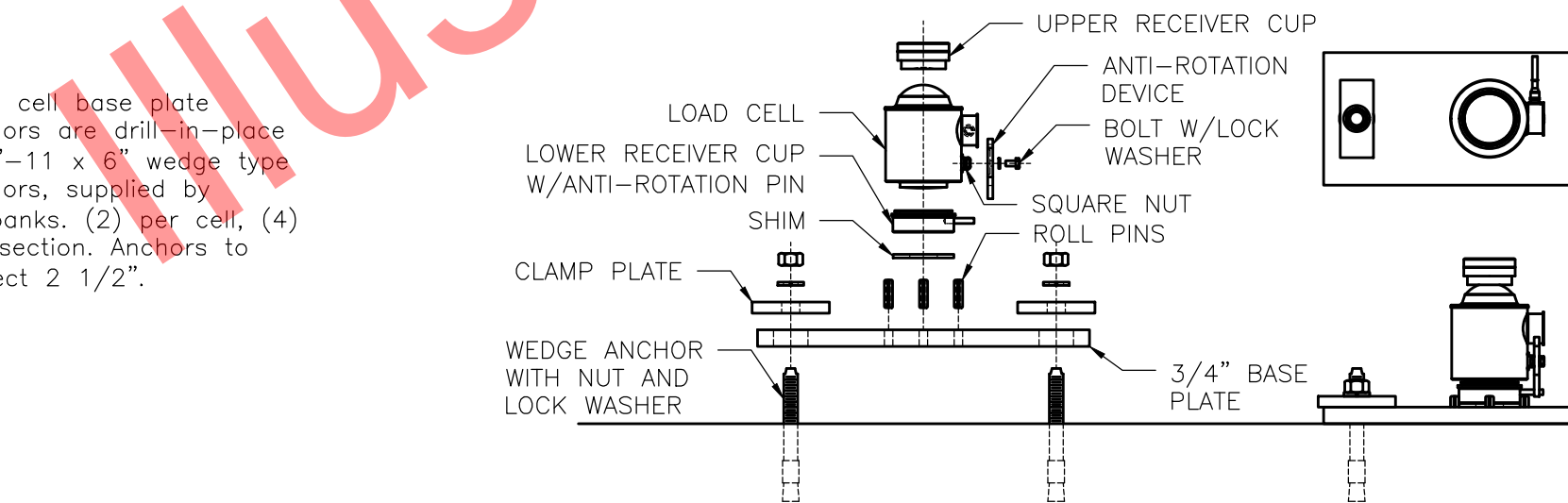

EXPLODED VIEW ASSEMBLY VIEW

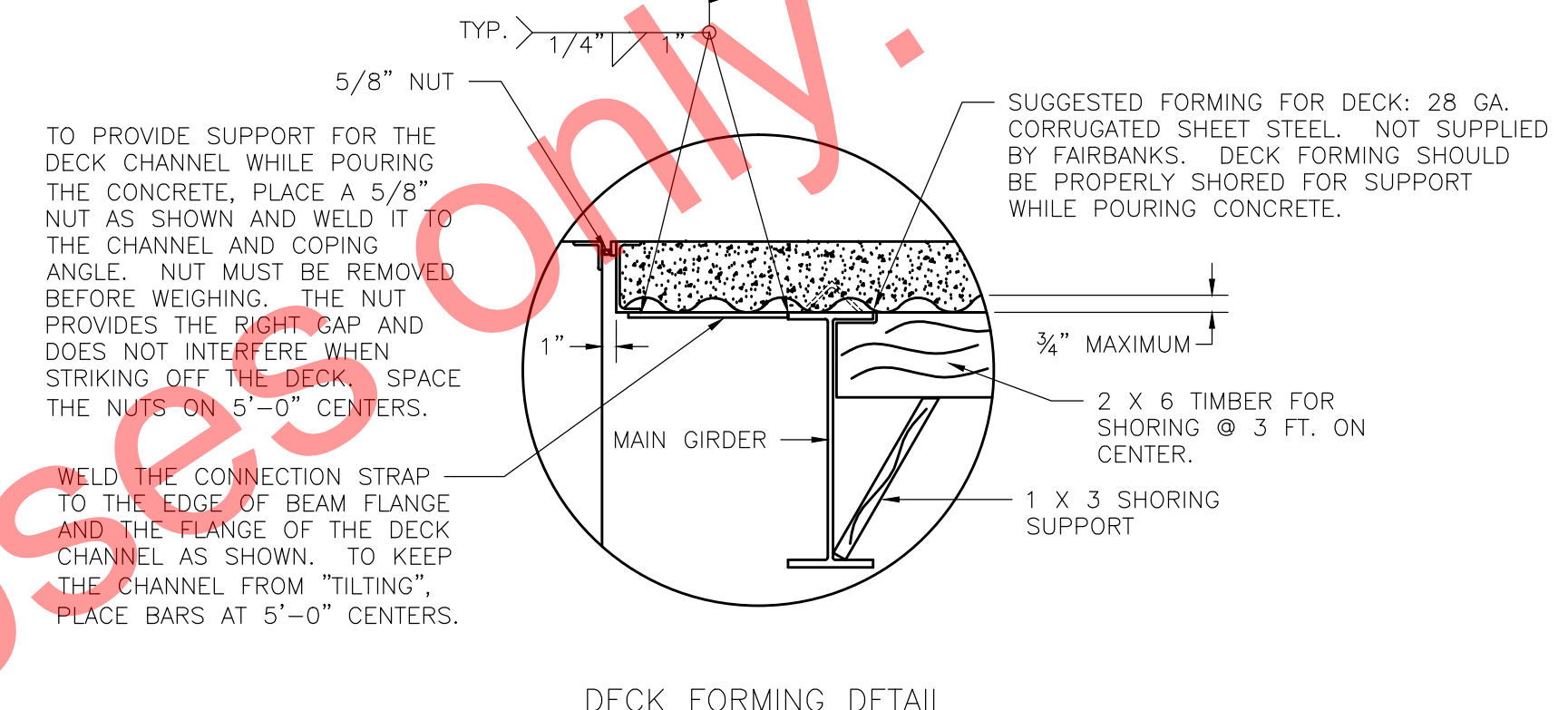

DECK FORMING DETAIL

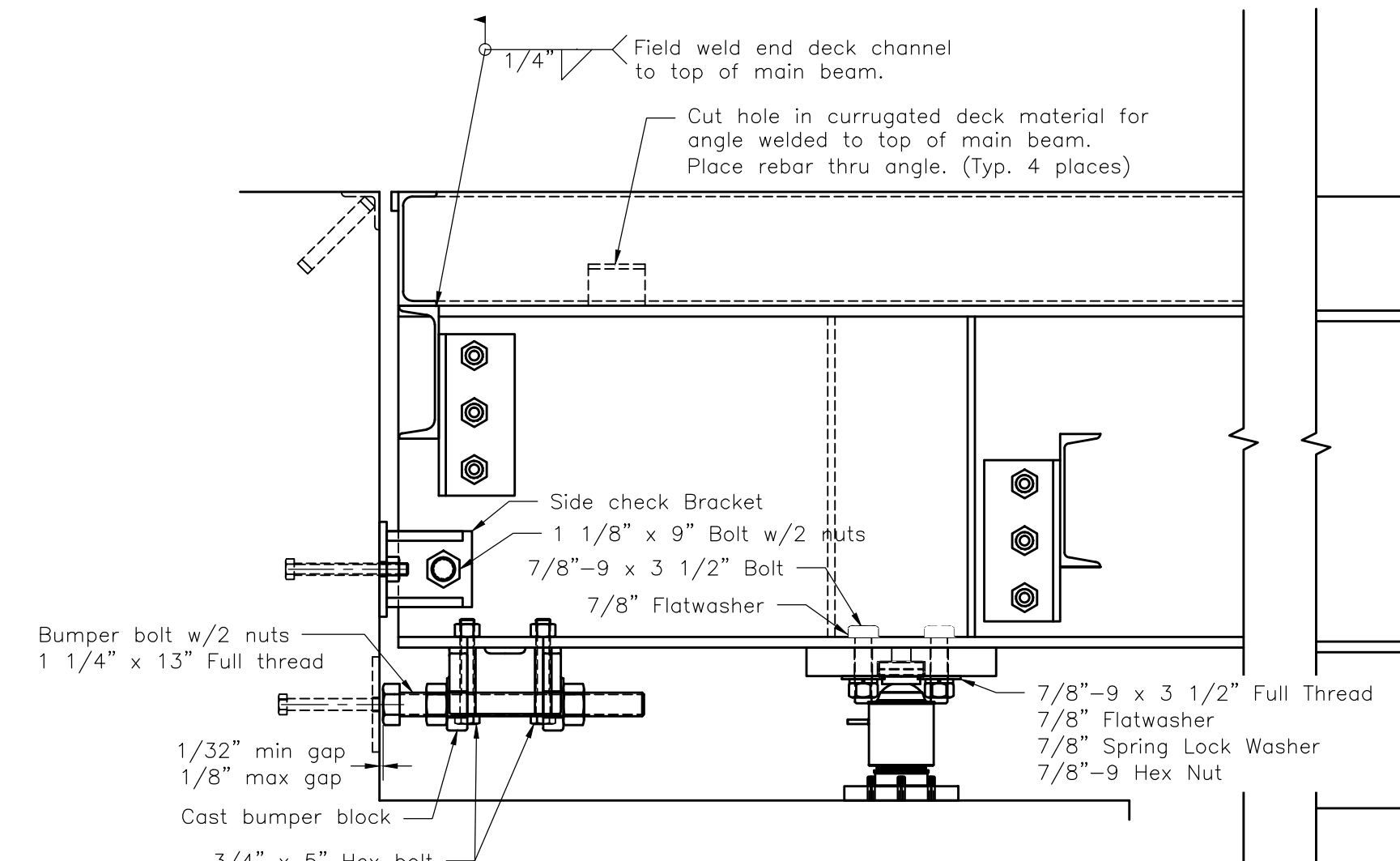

ASSEMBLY DETAIL at end section

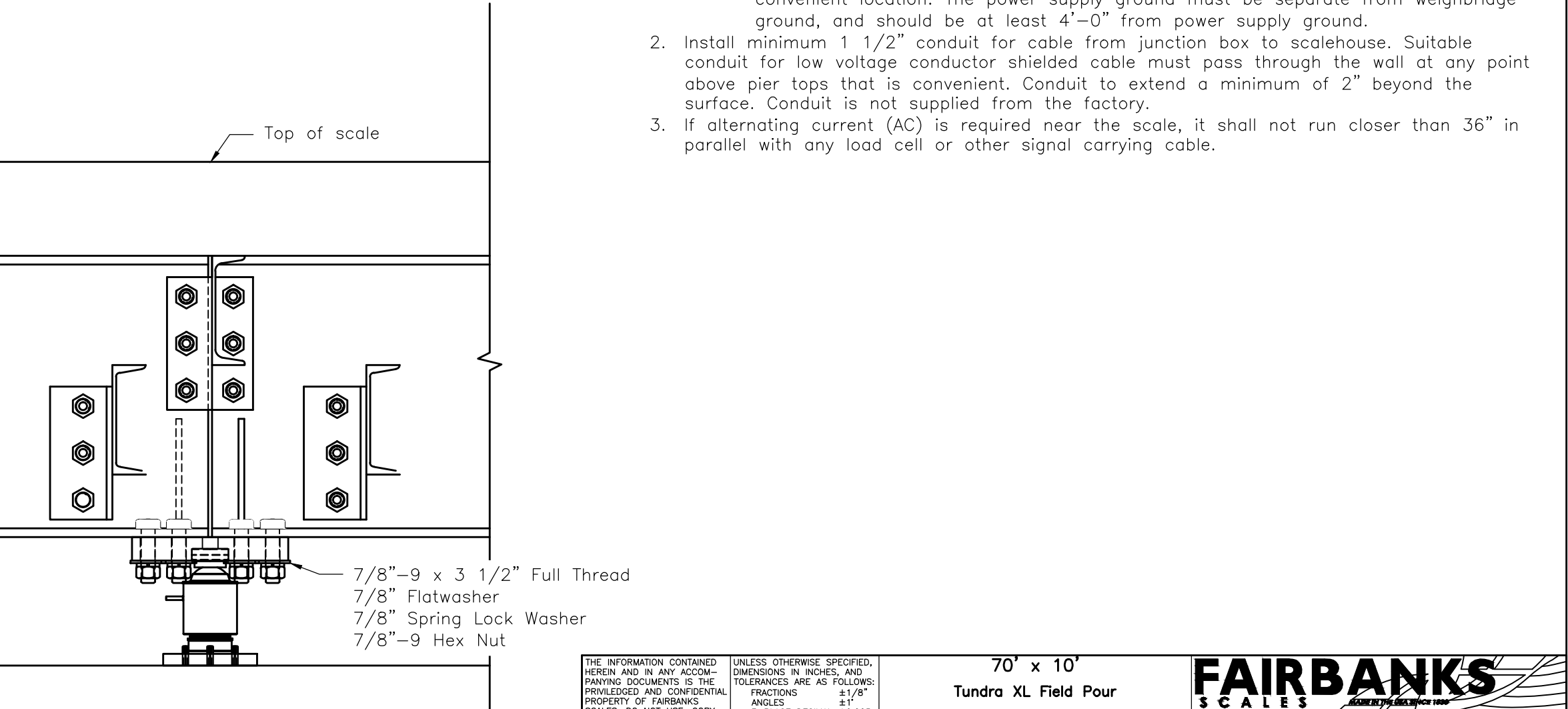

ASSEMBLY DETAIL at interior section

70' x 10' Tundra XL Field Pour
60,000lb CLC, 100ton Capacity

FAIRBANKS
Scales, Weighbridges, and Conveyors

SCALE: NTS DRAWN: JH CHECKED: JH
SHEET: 1 OF 1 DATE: 2/2/16 APPROVED: JH
DRAWING NUMBER: D-B166070-Sett

MODEL: PLT-2600-060-B10-070